



**prometal**

# 2863

**FAUTEUIL O.R.L.  
E.N.T. CHAIR**



**CARACTÉRISTIQUES STANDARD  
STANDARD FEATURES**

Hauteur variable hydraulique de 58 cm à 78 cm.  
*Hydraulic height adjustment from 58 cm to 78 cm.*

Mouvement du dossier et de repose-jambes combinées  
(commande bilatérale).  
*Combined backrest and legrest movement  
(bilateral control).*

Rotation 360° avec blocage par pédale.  
*360° rotation with pedal blocking system.*

Appui-tête réglable en hauteur  
et en inclinaison avec blocage manuel.  
*Height and angle adjustment of headrest  
with manual blocking mechanism.*

Repose-bras relevables.  
*Swing back armrests.*

Sellerie, épaisseur 5 cm,  
avec revêtement non-feu M1.  
*5 cm thick upholstery  
with flame-retardant, class M1 covering.*

Socle corolle chromé.  
*Chrome plated base.*



### Simplicité d'utilisation Easy to use

Une seule pompe hydraulique contrôle les mouvements du fauteuil : réglage de la hauteur, frein et rotation. L'appui-tête se règle en hauteur et en inclinaison.

*One single hydraulic pump controls all the chairs movements: height adjustments, brakes and rotation. The height and inclination of the head-rest can be adjusted.*

### Accessibilité & Confort Accessible & Comfortable

Un accès aisé au fauteuil grâce aux repose-bras relevables et au repose-jambe qui pivote sous le coussin d'assise. La sellerie anatomique offre un confort maximal pour votre patient pendant l'examen.

*Easy access to the chair is ensured with adjustable arm-rests and a retreating footrest. The upholstery moves together allowing for maximum patient comfort throughout the examination.*



### Robustesse Sturdiness

Le diamètre (4 cm) de la colonne hydraulique (tige de vérin) a été largement dimensionné pour garantir une extrême longévité du fauteuil.

*The diameter (4 cm) of the hydraulic cylinder, largely dimensioned, ensures a long life span of the chair.*

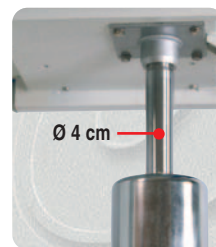

### OPTION

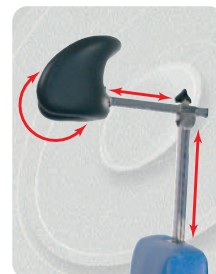

Appui-tête polyuréthane  
Polyurethane  
headrest..... (2859)

### CHOIX DES COULEURS - CHOICE OF COLORS



GALET



POLLEN



LAVANDE



ANTHRACITE



POTIRON



FUSCHIA



COBALT



ÉMERAUDE



SAPHIR



MALACHITE



TERRA COTTA

### DIMENSIONS (mm)

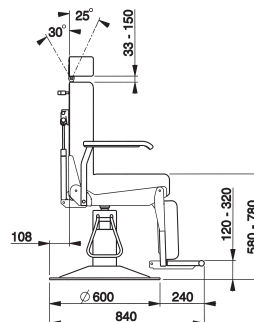
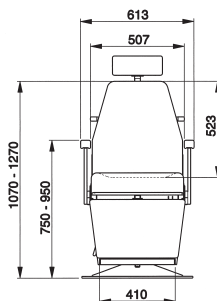
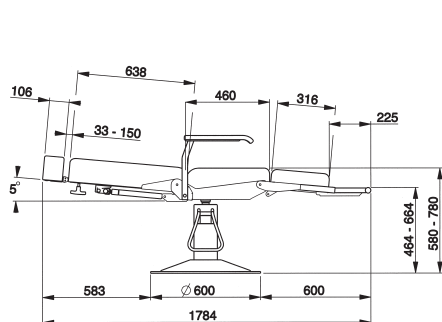

■ Poids net  
Net weight : 70 kg

■ Poids brut  
Gross weight : 90 kg

■ Volume : 1,071 m<sup>3</sup>



PROMOTAL - FRANCE  
www.promotal.com

MIDMARK® Group